

INSTALLATION INSTRUCTIONS

Electric Fuel Pump Controller – Part Number 12003

Congratulations on your purchase of this fuel pump safety controller. Adding this controller to your electric fuel pump wiring will greatly increase your safety in the event of an accident. After a three second priming, the controller will not allow the pump to run if the engine is not running.

Parts Included in this Kit

1-Controller Unit	1-Small crimp ring
1-T-Tap	1-Male 1/4" Connector
1-Large crimp ring	1-Female 1/4" Connector
2-Zip-ties	1-Diode

Mounting the Unit

The Electric Fuel Pump Controller may be mounted in any location where the electrical connections are easily accessible. Mounting in a weatherproof location is recommended. Use two self-tapping screws, rivets, or zip-ties through the mounting tabs to securely mount the unit.

Electrical Connections

The Electric Fuel Pump Controller will energize the fuel pump for three seconds when power is first applied. After these first three seconds, the fuel pump is energized only when the engine is running. Figure 1 shows a basic schematic of how the circuit operates.

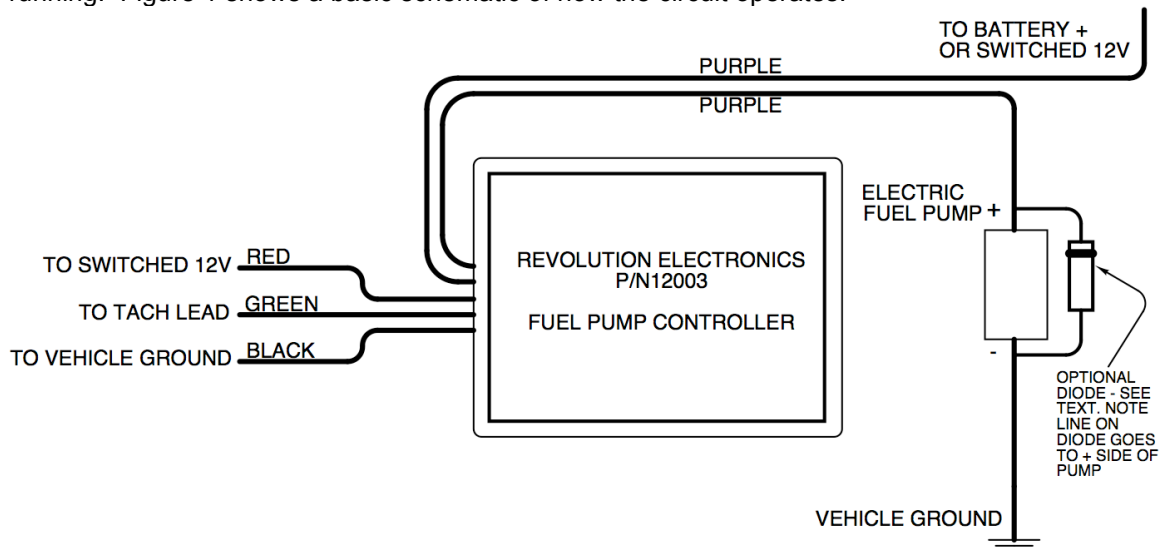

Figure 1

Red Wire - Connect this wire to a switched power source. The supplied female connector can be used to attach this wire to a switched 12v source on the fuse box. Less than 1/10th of an amp will be drawn from this wire.

Black Wire - Connect this wire to a vehicle ground. The small ring terminal can be used to attach this wire to a mounting bolt or another source of vehicle ground.

Green Wire -Connect this wire to the Tachometer lead. This wire senses the electrical pulses going to the tachometer and is used to determine when the engine is running. Attach the supplied T-tap connector to the tachometer lead running up to the dash. Next attach the insulated male connector to the end of the green wire and insert into the T-tap.

Purple Wires -Connect these wires inline with the fuel pump power supply wire. The purple wire has been supplied as a loop so you can adjust the lead lengths as necessary, making one lead very long and the other short. The larger ring terminal can be used to attach one purple wire to the starter solenoid as a good source of battery power. The other purple lead would be wired to the positive lead on the fuel pump. The controller contains an internal resettable 7.5A fuse to limit the current on the purple wires. If the fuse should trip, resetting the fuse is a simple matter of turning off power for a few seconds. Most fuel pumps for street use only draw about 2.5 amps but recommend a 7.5 amp fuse.

Troubleshooting

Fuel pump doesn't turn on:

- Purple wires not connected to +12V and/or the fuel pump
- Red wire not connected to a switched power source
- Black wire not connected to a good ground

Fuel pump always shuts off after three seconds:

- Green wire not connected to a tach signal

Fuel pump turns off and then back on over and over:

- Install the optional diode across the fuel pump terminals as shown in figure 1.

Bench Testing – This controller can be bench tested by connecting the red and black leads to the positive (+) and negative (-) sides of a 9v battery. You should hear the relay “click” immediately and then hear another click after three seconds. Tapping the green wire to the positive side of the 9v battery will simulate a running engine; when the controller senses the pulses on the green wire, another click will be heard and finally a click will be heard when the green wire is no longer being tapped to the 9v battery.

Warranty:

All Revolution Electronics products carry a warranty against defects in materials or workmanship for a period of one (1) year from the original retail purchase. Revolution Electronics' liability is strictly limited to the prompt repair or replacement of the defective product. Revolution Electronics shall not be responsible for (a) labor, transportation, or other incidental charges; (b) consequential or other damages incurred by use of any product. Revolution Electronics offers no other warranty beyond this limited warranty. This limited warranty does not apply to products which have been (a) modified or altered in any way; (b) subjected to adverse conditions, misuse, neglect, accident, improper installation or adjustment, contaminants, corrosion, or faulty repair; or (c) used in applications other than those recommended by Revolution Electronics. To initiate a warranty process, the consumer must first contact technical support (tech@revolutionelectronics.com) to receive a return authorization number. The product must be returned to Revolution Electronics complete with a dated receipt and a return authorization number.

www.revolutionelectronics.com
Cypress, California 90630